

# HD HERO2

USER MANUAL + WARRANTY INFO

GoPro<sup>®</sup>  
Be a HERO. ■■■■

Join the GoPro party at **[facebook.com/goprocamera](https://www.facebook.com/goprocamera)** to see what other GoPro owners are capturing with their GoPros. Share some of your own footage and contribute to the GoPro movement!

---

## TABLE OF CONTENTS

---

Accessories	4
Mounts	5
HD HERO2 Features	6
Firmware Update	8
Basics	8
Camera Modes	11
Advanced Menu Settings	17
Additional Menu Settings	24
Storage/SD Cards	30
System Requirements	31
Transferring Files	32
Battery Life	34
Important Warning Messages	36
Camera Assembly	37
FCC Statement	43
Warranty	44
Customer Support	45

## WEAR IT. MOUNT IT. LOVE IT.

### PREMIUM ACCESSORIES



3D HERO® System



LCD BacPac™



Battery BacPac™

### CORE ACCESSORIES



Floaty Backdoor



Rechargeable Li-Ion Battery



Anti-Fog Inserts



Lens Replacement Kit



Replacement HD Housing



HD Skeleton Housing



16GB SD Memory Card



32GB SD Memory Card

## MORE AT **GOPRO.COM**

### MOUNTS



Helmet Front Mount



Chest Mount Harness



Handlebar Seatpost Mount



Surf HERO Mounting Kit



HD Wrist Housing



Head Strap



Suction Cup Mount



Vented Helmet Strap



Roll Bar Mount



Tripod Mount



Military Helmet Mount



Grab Bag of Mounts



Curved Adhesive Mounts



Flat Adhesive Mounts

## HD HERO2 FEATURES

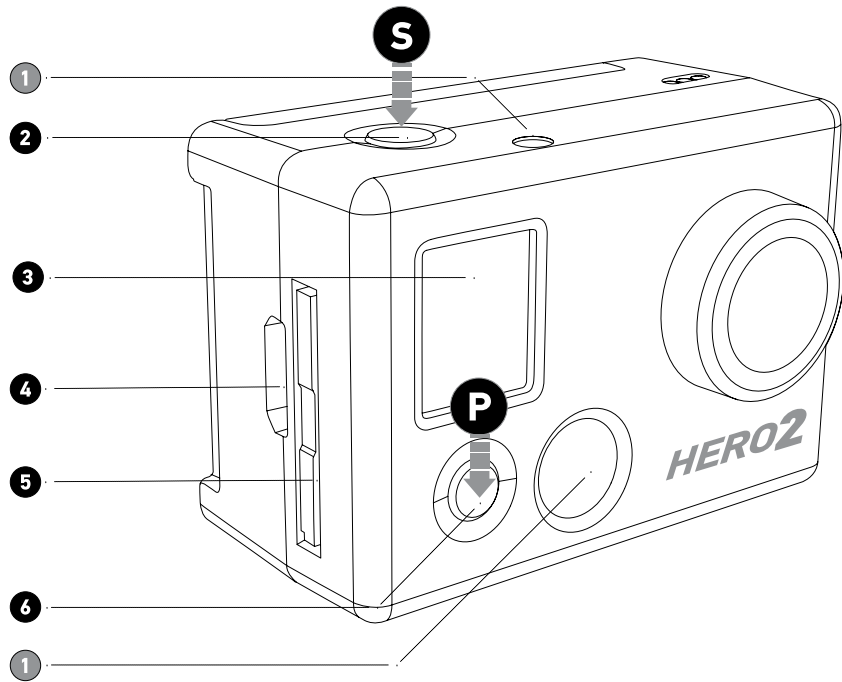

1. LED Recording Lights

2. SHUTTER/SELECT Button **S**

3. LCD Status Screen

4. HDMI Port  
(cable not included)

5. SD Card Slot

6. POWER/MODE Button **P**

## HD HERO2 FEATURES

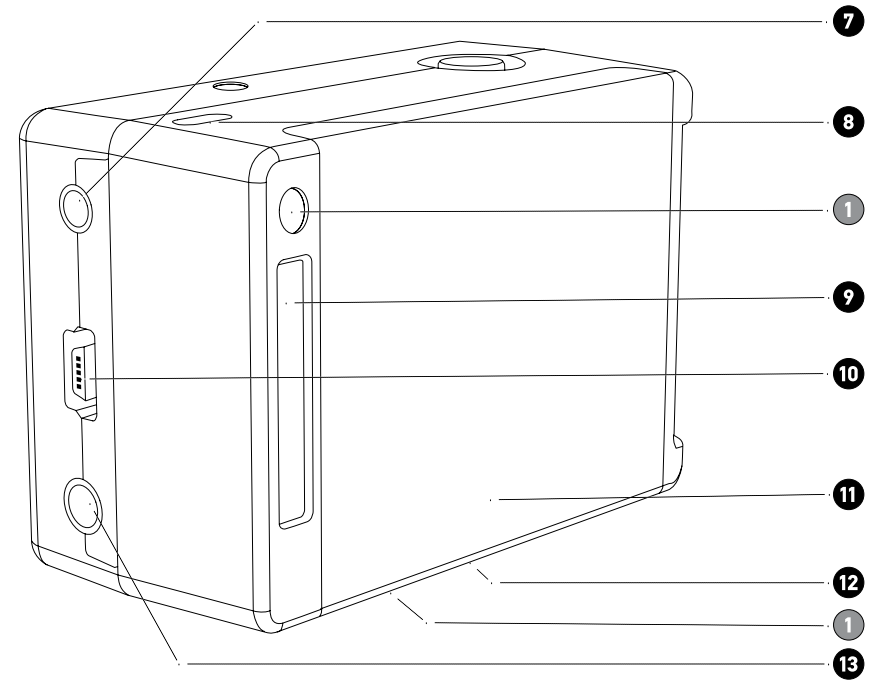

7. 2.5mm Composite Port  
(cable not included)

8. Microphone

9. HERO Port

10. USB Port (file transfer/charging)

11. Battery Door

12. Buzzer  
(located on camera bottom)

13. 3.5mm External Mic Input

---

## FIRMWARE UPDATE

---



GoPro releases new camera features through firmware updates. Visit [gopro.com/firmware](https://gopro.com/firmware) to download the latest updates.

---

## USING YOUR HD HERO2: BASICS

---

### GETTING STARTED

Before using the HD HERO2 for first time:

**1. Insert a SD memory card into the SD card slot.**

Your HD HERO2 is compatible with SD + SDHC memory cards (Class 4 or higher rated cards are recommended).

► See **STORAGE/SD CARDS** for more information.

**2. Install the battery into your HD HERO2 camera.**

**3. Charge the battery.**

The lithium-ion battery included with your HD HERO2 ships only partially charged. For a full charge, use the USB cable to plug the camera into a power source such as a computer or USB charging device. No damage will occur to your battery if you are not able to charge it before using your camera.

► See **BATTERY LIFE** for more information.

---

## USING YOUR HD HERO2: BASICS

---

### DEFAULT SETTINGS SNAPSHOT

Out of the box, your HD HERO2 camera is configured with the following featured default settings:

---

	<b>Camera Mode:</b>	Video
	<b>Video Resolution:</b>	960p-30fps
	<b>Field of View:</b>	170° Wide
	<b>Still Photo Resolution:</b>	11 Megapixels
	<b>Time Lapse Interval:</b>	1 second
	<b>Power Up Mode:</b>	Video

---

► See **SETTINGS MENU** for more information on the camera's default settings and instructions on how to change them.

---

## USING YOUR HD HERO2: BASICS

---

### POWERING ON AND OFF

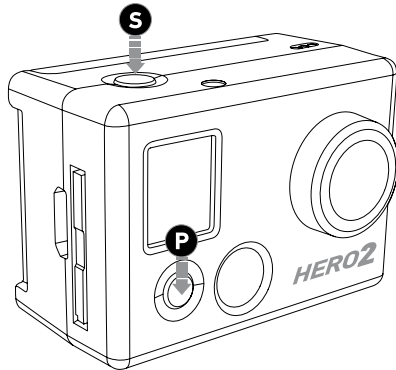

#### To power ON the HD HERO2:

Press and release **P**. The LED Recording Light ✨ on the front of the camera will flash three times and the Buzzer 🔊 will emit three short beeps.

#### To power OFF the HD HERO2:

Press and hold **P** for two seconds. The LED Recording Light ✨ will flash seven times and the Buzzer 🔊 will emit seven quick beeps.

#### PRO TIP:

You can change the HD HERO2 default settings to start in One Button Mode, which sets the camera to immediately begin recording once it is powered on.

► See **ONE BUTTON MODE** for more information.

---







## USING YOUR HD HERO2: CAMERA MODES

---

### OVERVIEW

Once the HD HERO2 is powered on, each press of **P** will cycle through the camera's recording modes and settings menu in the following order:

---

	<b>VIDEO</b>	Record video
	<b>PHOTO</b>	Take single photos
	<b>BURST</b>	Take 10 photos in 1 second
	<b>TIME LAPSE</b>	Take a photo every 0.5, 1, 2, 5, 10, 30, and 60 seconds
	<b>SELF TIMER</b>	Take a single photo after a 10-second countdown
	<b>SETTINGS</b>	Change the camera's configuration

---

Each camera mode can be changed in the Settings menu.

► See **ENTERING THE SETTINGS MENU** for more information.

## USING YOUR HD HERO2: CAMERA MODES

### RECORDING VIDEO

Verify that the camera is in Video Mode, indicated by  on the LCD. If not, press **P** repeatedly until the camera displays the Video Mode icon.

- **To begin recording video:**

Press and release **S**. The camera will emit one beep and the LED Recording Light will flash while recording continues.

- **To stop recording:**

Press and release **S**. The LED Recording Light will flash three times and the camera will emit three beeps to indicate recording has stopped.

HD HERO2 will automatically stop recording when either the SD card is full or the battery runs out of power. Your video will be saved before the camera powers off.



While recording video, the LCD will display the currently selected video resolution, lens field of view (FOV), the elapsed time of the current recording, and the remaining recording time determined by the free space on your SD card.



When recording is stopped, the LCD shows the number of video files stored on the SD card in place of the elapsed recording time.

**PRO TIP:**

When the camera is set to One Button Mode, hold **S** for two seconds to enter the Settings  screen, where you can quickly turn OFF One Button Mode.

► See **ONE BUTTON MODE** for more information.

## USING YOUR HD HERO2: CAMERA MODES

### TAKING SINGLE PHOTOS

Verify that the camera is in Photo Mode, indicated by  on the LCD. If not, press **P** repeatedly until the camera displays the Photo Mode icon.



**To take a photo:**

Press and release **S**. The camera will beep once and the LED Recording Light will flash once to indicate a photo has been taken.



**In Photo mode:**

The LCD screen will display your currently selected photo resolution (11MP, 8MP or 5MP), the number of photos stored on your SD card, and the number of photos that can be taken before the card is full.

**PRO TIP:**

If you think your SD card will fill up before you are able to transfer your files, select the 5MP option under the Photo settings menu. 5MP files are smaller than 11MP files, allowing your SD card to store more photos.

► See **PHOTO RESOLUTION MODES** for more information.

---

## USING YOUR HD HERO2: CAMERA MODES

---

### PHOTO BURST MODE

In Photo Burst Mode, the camera will take 10 photos in 1 second.

- Verify the camera is in Burst Mode, indicated by  on the LCD screen. If not, press **P** repeatedly until the camera displays the Burst Mode icon.
- Press and release **S** once to take a photo burst of ten photos over one second. The LED Recording Light will flash and the camera will beep 10 times to indicate the photos have been taken.



As in Photo Mode, the LCD screen will display your currently selected photo resolution (11MP, 8MP or 5MP), the number of photos stored on your SD card, and the number of photos that can be taken before the card is full.

#### PRO TIP:

Compared to single Photo Mode, Burst Mode gives you 10 times as many chances to capture that “can’t miss” moment.

---

## USING YOUR HD HERO2: CAMERA MODES

---

### TIME LAPSE PHOTO MODE

Time Lapse Photo Mode is used to take a series of photos at **0.5, 1, 2, 5, 10, 30 or 60 second** intervals (when using 0.5 seconds, it is recommended to use a class 10 or higher SD card).

► See **TIME LAPSE PHOTO MODE** in advanced settings for instructions on how to change the interval setting.

- Verify the camera is in Time Lapse Mode, indicated by  on the LCD screen. If not, press **P** repeatedly until the camera displays the Time Lapse Mode icon.
- Press the **S** button once to begin taking Time Lapse photos. The LED Recording Light will flash each time a photo is taken.
- Press **S** once to stop taking Time Lapse photos. The LED Recording Light will flash three times and the camera will emit three beeps to indicate Time Lapse has stopped.



As in Photo Mode, the LCD screen will display your currently selected photo resolution (11MP, 8MP or 5MP), the number of photos stored on your SD card, and the number of photos that can be taken before the card is full.

---

## USING YOUR HD HERO2: CAMERA MODES

---

### SELF-TIMER MODE

In Self-Timer Mode, the HD HERO2 will take a single photo at the end of a 10-second countdown.

- Verify that the camera is in Self-Timer Mode, indicated by  on the LCD. If not, press **P** repeatedly until the camera displays the Self-Timer Mode icon.
- To take a photo, press and release **S**. The camera will beep and the LED Recording Light will flash during the countdown, ending with a series of rapid beeps and flashes just before the photo is taken.
- To stop the countdown timer, press **S**.



As in Photo Mode, the LCD screen will display your currently selected photo resolution (11MP, 8MP or 5MP), the number of photos stored on your SD card, and the number of photos that can be taken before the card is full.

---

---

## ADVANCED MENU SETTINGS

---

### ENTERING THE SETTINGS MENU



Using the Settings Menu, many of the functions of the HD HERO2 can be customized based on your shooting needs.

---





#### To access your HD HERO2 settings:

1. Make sure your camera is powered ON.
2. Cycle through camera modes using **P** until the LCD Status Screen shows the SETTINGS  icon.
3. To enter into the Settings Menu, press **S**.
4. Use **P** to toggle through each camera setting mode.
5. Every settings mode has a list of options. Press **S** to enter into a specific mode. The option which is currently active will be highlighted. Press **P** to toggle through the list. Press **S** to select highlighted option and exit list.
6. Press **P** to cycle to the next camera setting mode or press **S** to display current option list again.

## ADVANCED MENU SETTINGS

 **DEFAULT MODE AT POWER UP**

Select which camera mode is active (or default) when you power on your camera.

 <b>VIDEO</b> (Default)	 <b>PHOTO</b>	 <b>BURST</b>	 <b>TIME LAPSE</b>
---	---	---	--

 **VIDEO RESOLUTION MODES**

Your HD HERO2 camera shoots the following video resolutions:

Resolution/ FPS	Field of View	Screen Resolution	Best Use
1080-30	170° / 127°	1920x1080	Highest resolution.
960-48 (Slow motion)	170° wide angle	1280x960	This resolution provides the widest top-to-bottom and side-to-side viewing area. Great for slow motion.
960-30 (Default)	170° wide angle	1280x960	This resolution provides the widest top-to-bottom and side-to-side viewing area.

## ADVANCED MENU SETTINGS

 **VIDEO RESOLUTION MODES : CONT'D**

Resolution/ FPS	Field of View	Screen Resolution	Best Use
720-60 (Slow motion)	170° wide angle	1280x720	For mounting on vehicles or gear when a max side-to-side wide angle is desired but vertical viewing area is not as important. Great for slow motion.
720-30	170° wide angle	1280x720	For mounting on vehicles or gear when a max side-to-side wide angle is desired but vertical viewing area is not as important.
WVGA-120 (Super slow motion)	170° wide angle	848x480	For smaller data files. This is standard definition resolution. Great for super slow motion.
WVGA-60 (Super slow motion)	170° wide angle	848x480	For smaller data files. This is standard definition resolution. Great for slow motion.

 When you are using the camera in Video Mode, the currently selected video resolution appears on the LCD Status Screen beneath the Video mode icon.

**PRO TIP:** Consider using 960-48 when wearing camera on a helmet or a chest harness to see your handlebars when biking, or knees and skis when skiing.

## ADVANCED MENU SETTINGS

### FIELD OF VIEW MODES

When recording video in 1080p, you can set the camera to shoot in the default wide-angle (170°) or a medium-wide angle (127°) field of view.

► See **VIDEO RESOLUTION MODES** for more information.

WIDE 170° (Default)

MEDIUM 127°

### PHOTO RESOLUTION MODES

The HD HERO2 can take photos in either 11MP, 8MP or 5MP resolutions. Changing this setting effects photos taken in Photo, Burst, Self Timer and Time Lapse Modes.

11MP (Default)

8MP

5MP



When you are using the camera in one of the photo modes, the currently selected photo resolution appears on the LCD beneath the Photo Mode icon.

## ADVANCED MENU SETTINGS

### TIME LAPSE MODES

You can select a wide range of time intervals for your Time Lapse Mode photos.

Choose between 0.5, 1 (Default), 2, 5, 10, 30 and 60 seconds.

### UPSIDE DOWN VIDEO/IMAGE MODE

If you need to mount your camera upside down, you can set the camera to save the photo or video upside down so that it appears right side up when you review it on your computer or TV. This eliminates the need to “flip” the photo or video later on your computer.

 (Default) Camera right side up

 Camera upside down

### SPOT METER SETTINGS

Turn on the Spot Meter when you are filming from a dark space into a brighter setting, like when filming outside a windshield from inside a car.

OFF (Default)

ON

**Note:** The Spot Meter icon  is displayed in the upper-right corner of the LCD when Spot Metering is on.

## ADVANCED MENU SETTINGS







### ONE BUTTON MODE

One Button Mode forces the camera to automatically begin recording in its default power up mode once the camera is ON. When One Button Mode is ON,  is disabled. To stop recording, you must turn your camera OFF.

OFF (Default)

ON

#### To turn One Button Mode ON:

1. Access the Settings Menu  (▶ See **ENTERING THE SETTINGS MENU** for more information.)
2. Use  to cycle through the settings menus until the One Button Mode  menu appears.
3. Press  to access the One Button Mode menu.
4. Press  once to select ON and press  once to confirm selection.
5. Press  to cycle through settings menu. Select and press EXIT.









#### PRO TIP:

In One Button Mode, the camera is either “on and recording” or powered OFF. This simplifies camera operation when loaning the camera to a friend or when you know you only want to shoot in one mode.

## ADVANCED MENU SETTINGS

### ONE BUTTON MODE (CONT'D):

#### To turn One Button Mode OFF:

1. While the camera is ON and recording, press and hold  for two seconds until the settings icon  appears.
2. Enter the settings menu by pressing .
3. Use  to cycle through the settings menu until  appears. Press  to enter One Button Mode menu.
4. Press  once to select OFF and press  to confirm selection.
5. Press  to cycle through the settings menu. Select and press EXIT.

## ADDITIONAL MENU SETTINGS



### MORE MENU SETTINGS

To access additional settings, enter MORE  menu. The following settings are found in this subsection:



### DELETE





Delete last file or delete all files and reformat SD card.

CANCEL (Default)

LAST

ALL/REFORMAT



#### To delete the last file saved:

1. With the Delete  settings menu screen displayed, press  to enter into the delete list.
2. Within the delete menu you can toggle through the list by using  to choose one of the following options:
  - **CANCEL:** To cancel out of delete, Press  and return to the main settings menu.

## ADDITIONAL MENU SETTINGS



### DELETE (CONT'D):

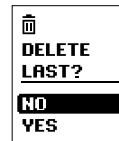

- **LAST:** To delete the last file saved, Press  to select menu option. The LCD will display a confirmation menu. Within this menu you can toggle through the menu options using .

#### The menu options are:



**NO:** Press  to cancel and return to the main settings menu.

**YES:** Press  to select yes. The last file saved will be deleted.

- **ALL/Format SD Card:** To delete all files on the SD Card, press  to select menu. The LCD will display a confirmation menu. Within this menu you can toggle through the menu options using .

#### The menu options are:



**NO:** Press  to cancel and return to the main settings menu

**YES:** Press  to select yes. All files will be deleted. During the delete all process, the LED lights will continue to blink until formatting is complete.

---

## ADDITIONAL MENU SETTINGS

---

### NTSC / PAL

This setting controls both the video recording frame rate and playback of video from the camera when viewing on a TV. Select NTSC if viewing on a TV in North America. Choose PAL if viewing on a PAL TV (most televisions outside of North America) or if viewing on a PAL TV in any region.

NTSC (Default)

PAL

### ON SCREEN DISPLAY (OSD)

Select if you would like to display or hide the recording icons and information on your video screen (when displaying live video on a TV screen or using the LCD BacPac™). OFF will hide icons and ON will display icons.

OFF (Default)

ON

### LED LIGHTS

You can choose between having all 4 LED lights active, only 2 LED lights active (front and back) or turn OFF all the LED lights.

4 (Default)

2

OFF

---

## ADDITIONAL MENU SETTINGS

---

### CAMERA SOUND

You can change volume level of the camera's beep to be softer than the default or silent for stealth mode.

100% (Default)

70%

OFF

### AUTO POWER OFF

Program the camera to automatically turn OFF after a specific period of inactivity (when no videos or photos are being taken and no buttons have been pressed). If you set the camera to MANUAL, you will need to manually turn your camera OFF.

MANUAL (Default)

60sec

120sec

300sec

## ADDITIONAL MENU SETTINGS



### DATE / TIME / MONTH

You can set the camera's internal clock to ensure that your video and photo files are saved with the correct date/time information. You will need to adjust the date/time information if the battery is removed from the camera for an extended period of time.



**00/00/11**  
MM/DD/YY    Month / Day / Year  
**00:00**



**00/00/11**  
MM/DD/YY    Hour / Minute  
**00:00**  
HH:MM

1. Press **P** repeatedly until Date/Time/Month  appears on the LCD.
2. Press **S** to begin setting the date and time.
3. The LCD will show the Date/Time/Month setting menu with the Month field highlighted. Press **S** to access the list of months (1 to 12).
4. Use **P** to cycle through the list until the correct month is highlighted.
5. Press **S** to select the highlighted month.
6. The Date/Time/Month setting menu will appear on the LCD. Press **P** once to highlight the Day field and press **S** to access the list of days (1 to 31).
7. Again use **P** to highlight the correct day and **S** to select it.
8. Repeat this process for the Year, Hour and Minute.

#### PRO TIP:

The Date/Time/Month fields are abbreviated. For example, the month is MM, day is DD, Year is YY, hour is HH, minute is MM.

## ADDITIONAL MENU SETTINGS

### EXIT

#### EXIT SETTINGS MENU

From the EXIT screen, press **P** to return to the camera's default camera mode.

## STORAGE/SD CARDS

The HD HERO2 camera is compatible with 2GB, 4GB, 8GB, 16GB and 32GB capacity SD and SDHC memory cards. While all speed cards will work in the camera, GoPro recommends higher speed cards (labeled as Class 4 or higher) when shooting HD video. GoPro recommends using name brand SDHC cards for maximum reliability in high vibration activities.

### To insert a SD card:

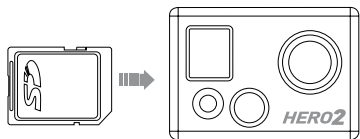

1. Insert SD card into the SD card slot with the SD card label facing the front of the camera.
2. The SD card will click into place once it is fully inserted.

### To remove a SD card:

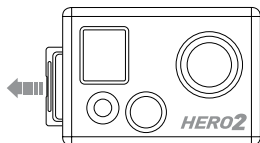

1. Place your fingernail against the edge of the SD card and lightly press it further into the camera.
2. The card will spring out from the camera far enough for you to pull it out.

## SYSTEM REQUIREMENTS

The HD HERO2 camera is compatible with Microsoft® Vista, 7 or later and Mac OS X 10.5 or later.

System Requirements for full High Definition 1080p and 720p 60fps playback:

WINDOWS	MAC
Microsoft Windows® Vista 7+	Mac OS® X 10.4.11 or later
3.2GHz Pentium 4 or faster	2.0GHz Intel Core Duo or faster
DirectX 9.0c or later	At least 2GB of system RAM
Video card with at least 128MB of RAM	Video card with at least 128MB of RAM
At least 2GB of system RAM	

### PRO TIP:

If you are having problems achieving smooth playback on your computer, the HD HERO2 camera can also plug directly into a High Definition TV with an HDMI port using a mini-HDMI cable or via composite cable (not included). The HD HERO2 camera itself provides very smooth playback on an HDTV.

---

## TRANSFERRING FILES

---

### TO TRANSFER VIDEO AND PHOTO FILES TO A COMPUTER

#### On a PC:

1. Connect the camera to a computer with the included USB cable.
2. Turn on the camera by pressing **P**.
3. On your PC, double click My Computer and locate the “Removable Disk” icon. If you do not see it, close the My Computer folder and then reopen it. The “Removable Disk” icon should appear.
4. Double click the “Removable Disk” icon.
5. Double click the “DCIM” folder icon.
6. Double click the “100GOPRO” icon.
7. Your photo and video files will be in the “100GOPRO” folder.
8. Copy/Move files to the computers hard drive and then select video/photo for playback from desktop/hard drive.

#### On a Mac:

1. Plug the camera into your Mac with the included USB cable.
2. Turn on camera on by pressing **P**.
3. The Mac will recognize the camera as an external hard drive. Double click the icon for the external drive to access your video and photo files.
4. Copy/Move files to the computers hard drive and then select video/photo for playback from desktop/hard drive.

**IMPORTANT TIP FOR MAC USERS:** When deleting files from your SD card you must empty the trash before removing the SD card or unplugging the camera. If you do not empty your trash the photo and video files will not be completely erased from your SD card.

---

## TRANSFERRING FILES

---

### TO VIEW PHOTOS AND VIDEO ON A TV OR HDTV

Using an HDMI cable (not included), plug your HD HERO2 camera into your TV. You can also use the composite port and a composite cable (not included).

#### Once connected:



With the camera powered ON, navigate to the Playback Setting  using **P**. Press **S** to enter the Playback menu.

Within the playback menu, use **P** to toggle through the menu list. Use **S** to select each item. **The menu list options are:**

**Video:** Displays all video files on the SD card. During playback, volume adjustment can be made via the TV. Playback will begin automatically.

**Photo:** Displays all photo files on the SD card.

**All (Default):** Displays all photo and video files on the SD card.

**Exit:** Exits the playback menu.

#### PRO TIP:

To Forward, press **P**

To Fast Forward, hold down **P**

To Reverse, press **S**

To Rewind, hold down **S**

To Exit playback at anytime, eject the HDMI/Composite cable from the camera

To Navigate back to the menu list while in playback, hold down both **S** and **P** together for 3 seconds

**NOTE:** Make sure your camera is set to the correct NTSC (North America) or PAL (outside North America) video settings or your camera will not work properly with your TV. You must also have an SD card with recorded information loaded into your HD HERO2 camera. If there are no video or photo files stored on your SD card you will see a **No Video, No Photo, or No Files** message.

► See **NTSC/PAL** for more information.

---

## BATTERY LIFE

---

Fully charged, the HD HERO2's battery will provide approximately 2.5 hours of video recording time in 720p30. The LCD displays the battery meter  in every camera mode so that you can monitor how much power remains in the battery. The battery meter will blink when the battery drops below 20% charge.

Spare batteries and additional charging accessories are available at [gopro.com](http://gopro.com) and from authorized GoPro resellers.

### CHARGING BATTERY

The LCD's battery icon will blink when the battery drops below 20%. If you are recording when the battery reaches 0%, the camera will save the file and turn OFF.

#### To charge the battery:

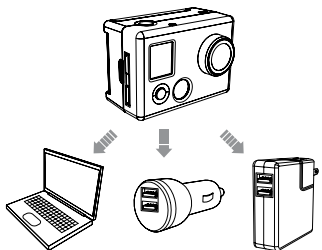

1. Connect the camera to a computer or USB power supply with the included USB cable.
2. LED remains ON while the battery is charging.
3. LED will turn OFF when the battery is fully charged.

The camera's battery will charge to 80% charge in 1-2 hours and 100% in four hours (depending on USB power output). It will charge to 80% in one hour and 100% in two hours when using GoPro's 1000mAh USB-compatible wall or car charger. Learn more about GoPro's 1000mAh chargers at [gopro.com](http://gopro.com).

---

## BATTERY LIFE

---

### USING THE CAMERA WHILE CHARGING

You can charge the camera's battery while recording video or taking photos. Simply plug the camera into any USB-based wall, car, or phone charger to charge the HD HERO2 camera while recording video or photos. It is best to use GoPro's 1 amp (1000mAh) charger for maximum charging performance while the camera is in use.

### REMOVING THE BATTERY FROM THE CAMERA

The HD HERO2 battery is designed to have a very tight fit to maximize reliability in high vibration activities. In most cases it is not necessary to remove the battery.

#### To remove the battery:

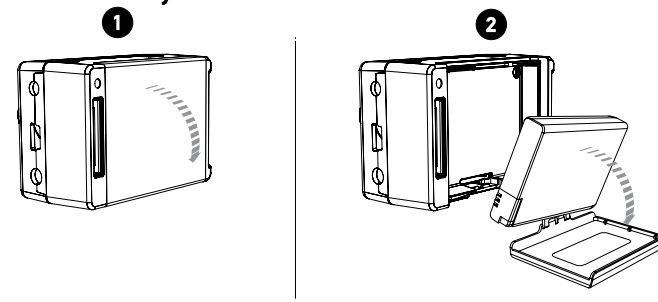

1. Remove the battery door by placing your thumb on the indentation in the battery door (on the bottom of the camera) and firmly pressing it away from the camera.
2. Squeeze both sides of the battery and pull it out of the camera. It is intentionally not easy to do, but the battery will come out.

---

## IMPORTANT WARNING MESSAGES

---

### “NO SD” MESSAGE ON THE LCD

#### NO SD

“NO SD” indicates that there is no SD card present. The HD HERO2 requires an SD card to record video or take photos.

► See **STORAGE/SD CARDS** for more information.

### FILE REPAIR ICON ON THE LCD



If you see the File Repair icon, your video file was corrupted during recording for some reason. Press any button and the camera will repair the file.

### TEMPERATURE WARNING ICON ON THE LCD



The Temperature Warning icon will appear on the LCD when the camera has become too hot and needs to cool down. Simply let it sit and cool before attempting to use it again. Your camera will not allow itself to overheat—so do not worry, as no damage has occurred.

---

## CAMERA ASSEMBLY

---

### ASSEMBLING THE CAMERA

The HD HERO2 camera housing is waterproof to 197 feet / 60 meters and constructed of polycarbonate and stainless steel for ultimate durability.

**To assemble the camera into the housing:**

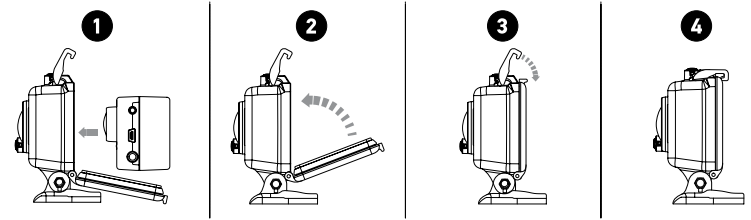

1. Place the camera into the housing.
2. Close the housing door.
3. Hook latch under groove on the backdoor.
4. Push down on thumb latch until it locks into place.

## CAMERA ASSEMBLY

Your HD HERO2 housing comes with two types of backdoors—waterproof and skeleton. To swap out a backdoor, click the door off its hinge. To attach the other backdoor, click it back on the hinge.

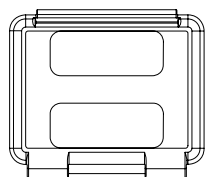

**Skeleton Backdoor**

The Skeleton backdoor (non-waterproof) provides better sound quality by allowing more sound to reach the camera's microphone. It also reduces wind noise at speeds up to 100mph when mounted on helmets, motorcycles, bike and other fast-moving vehicles. Use this backdoor only when water damage is not a risk. This backdoor is also recommended for use inside vehicles.

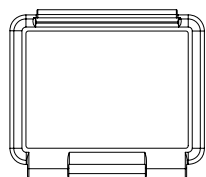

**Waterproof Backdoor**

The waterproof backdoor makes the housing waterproof to 197 feet / 60 meters. Use this door when you need to protect the camera from water and other environmental hazards.

**PRO TIP:**

Apply RAIN-X or a similar anti-beading solution to the housing lens to prevent water-spots from forming when using your camera in rain or water. When RAIN-X is not available, periodically licking your lens is a good backup solution.

## CAMERA ASSEMBLY

### SWAPPING HOUSING DOORS

Your HD HERO2 housing comes with two types of backdoors—waterproof and skeleton.

**To swap out a backdoor:**

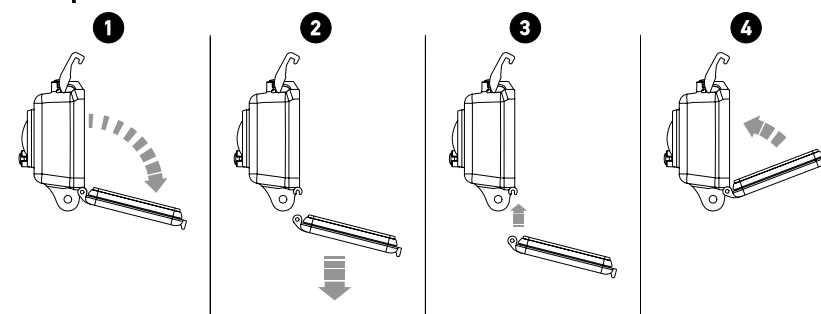

1. Open the backdoor of the housing so that it is hanging downwards.
2. Pull downwards on the backdoor until it snaps free from the hinge.
3. Line up replacement backdoor into the hinge opening.
4. Push upwards on the backdoor until it clicks into place.

---

## CAMERA ASSEMBLY

---

### PREVENTING WATER DAMAGE TO YOUR CAMERA

The rubber seal that lines the camera housing forms a waterproof barrier that protects your HD HERO2 in wet and underwater conditions. You must keep the rubber seal of the camera housing clean. A single hair or grain of sand can cause a leak.

After every use in salt water, you will need to rinse the outside of the housing with non-salt water and dry. Not doing this can eventually cause corrosion of the hinge pin and salt buildup in seal, which can cause failure.

To clean the seal, rinse it in fresh water and shake it dry (drying with a cloth can cause lint to compromise the seal). Re-install it into the grooves in the backdoor of the housing.

**WARNING:** Failure to follow these steps each time you use your HD HERO2 can result in leaks that damage or destroy your camera. Your warranty does not cover water damage resulting from user error.

---

## CAMERA ASSEMBLY

---

### ATTACHING YOUR CAMERA TO MOUNTS

To attach your HD HERO2 camera to a mount, you will need an attachment buckle, thumb screw and other hardware depending on the mount you are using. For more information on mounts, visit [gopro.com/support](http://gopro.com/support).

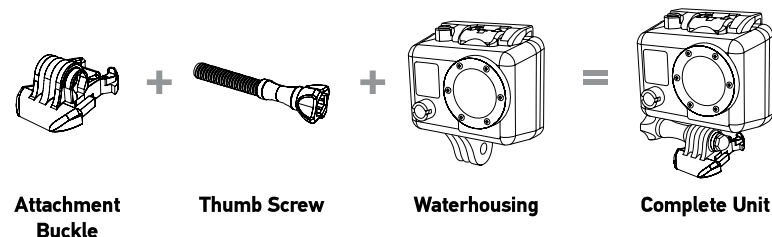

### USING CURVED OR FLAT ADHESIVE MOUNTS

The curved and flat adhesive mounts make it easy to attach the camera to curved and flat surfaces of helmets, vehicles and gear. With the attachment buckle the assembled camera housing can be clicked ON / OFF the secured adhesive mounts.

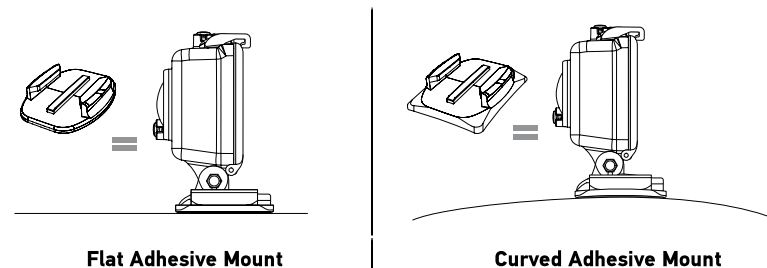

### PRO TIPS: ATTACHING ADHESIVE MOUNTS

**Clean the surface first.** Be sure to carefully clean the surface where you will be attaching your adhesive mount. Wax, oil, dirt and other debris will reduce adhesion, which can result in a weak bond and the risk of losing your camera if the bond fails.

**Only attach a mount in room temperature conditions.** The mount's adhesive will not bond properly if applied in cold or damp environments, though it is entirely safe to use in cold conditions. For best results, attach your mount 24 hours before use in cold environments to ensure the strongest hold.

**Surfaces.** The adhesive mounts can only be mounted to a smooth surface. Porous or textured surfaces will not provide for a proper bond. When applying the mount, firmly press mount into place ensuring full contact over entire surface area. Allow at least 24 hours for full bond strength.

**Drying time.** For best results, attach your mount at a minimum of 24 hrs before use.

## LOCKING PLUG



This locking plug is designed for high impact sports like surfing or skiing where significant impact can occur. The locking plug locks the attachment buckle's fingers in place, helping to prevent accidental housing release from mounts.

Modifications not approved by the party responsible for compliance could void user's authority to operate the equipment. This equipment has been tested and found to comply with the limits for Class B digital device, pursuant to part 15 of the FCC Rules. These limits are designed to provide reasonable protection against harmful interference in a residential installation. This equipment generates and can radiate radio frequency energy and, if not installed and used in accordance with the instructions, may cause harmful interference to radio or television reception, which can be determined by turning the equipment on and off.

The user is encouraged to try to correct the interference by one or more of the following measures:

- Reorient or relocate the receiving antenna.
- Increase the separation between the equipment and the receiver.
- Connect the equipment into an outlet on a circuit different from that to which the receiver is connected.
- Consult the dealer or an experienced radio/TV technician for help.

---

## WARRANTY

---

This product is guaranteed against manufacturing defects for one (1) year from the original date of purchase. GoPro's sole obligation in the event of such defects during this period is to repair or replace the defective part or product with a comparable part or product at GoPro's sole discretion. Except for such replacement, the sale, or other handling of this product is without warranty, condition or other liability even though the defect or loss is caused by negligence or other fault. Damage resulting from use, accident, or normal wear and tear is not covered by this or any warranty. GoPro assumes no liability for any accident, injury, death, loss, or other claim related to or resulting from the use of this product. In no event shall GoPro be liable for incidental or consequential damages relating to or resulting from the use of this product or any of its parts. Because of possible user resealing error, this product is not warranted against water housing leakage or any resulting damage.

Visit [gopro.com](https://gopro.com) for more information.

---

## CUSTOMER SUPPORT

---

GoPro is dedicated to providing you with the best possible service. To contact GoPro's Customer Support Team, visit: [\*\*gopro.com/support\*\*](https://gopro.com/support)